

FibreLink III Standalone Version Operations Manual



**TELEDYNE
MONITOR LABS**

A Teledyne Technologies Company

(This page intentionally left blank.)

DOCUMENT NO.: 1808-0010-01 REV A

DECEMBER 2011

Proprietary Information. All rights reserved by Teledyne Monitor Labs. No part of this book may be reproduced or copied in any form or by any means—graphic, electronic, or mechanical, including photocopying, taping, or information storage and retrieval systems—without written permission of the publisher.

Made in the United States of America

LonWorks® is a trademark of the ECHELON Corporation registered in the United States and other countries.

(This page intentionally left blank.)

TABLE OF CONTENTS

	Page
1.0 CAUTIONS AND WARNINGS.....	1-1
2.0 DESCRIPTION.....	2-1
3.0 SPECIFICATIONS.....	3-1

APPENDIX A Spare Parts

APPENDIX B Drawings

<u>Drawing No.</u>	<u>Sheet</u>	<u>Rev</u>	<u>Description</u>
1808-0003-01	4 of 6	E	Ultraflow 150 With FibreLink III Option (Supplemental Drawing)
1808-0003-01	5 of 6	E	LightHawk® 560 With FibreLink III Option (Supplemental Drawing)
1808-0003-01	6 of 6	E	Model 550 With FibreLink III Option (Supplemental Drawing)
1810-0016-01	1 of 1	C	LaserHawk® 360 With FibreLink III Option (Supplemental Drawing)
1808-0009-01	1 of 1	B	FibreLink III Installation Drawing

(This page intentionally left blank.)

1.0 CAUTIONS AND WARNINGS

WARNING: *Never view the fiber emitters (ST-TX connectors) under magnification with power on. To do so could result in damage to the human eye.*

WARNING: *Disconnect mains power from the FibreLink III during installation and replacement of components. Failure to do so may result in damage to personnel and/or equipment.*

CAUTION: *The ST fiber connectors are constructed of molded plastic. While they are durable, it is wise to attach and remove ST fiber optic cable connectors with care to avoid damage, especially if said connectors are of metal construction.*

SAFETY:

This equipment is intended only for the purposes specified in this manual. Safety protections inherent in this equipment may be impaired if used in a manner different than specified herein.

The following are internationally recognized symbols used on the FibreLink III along with specific cautions applicable to the equipment.



Label Standard Number:

ISO 3864 B.3.1

Generic meaning:

CAUTION: RISK OF DANGER. CONSULT MANUFACTURER'S DOCUMENTATION.

Cautions Invoked By This Label for FibreLink III:

1. Junction Box Cover is to be removed only by trained service personnel.
2. This equipment must be installed by a qualified electrician.



Label Standard Number:

ISO 3864 B.3.6

Meaning:

CAUTION: RISK OF ELECTRIC SHOCK.

Hazardous AC supply inside. Disconnect mains power before servicing.

(This page intentionally left blank.)

2.0 DESCRIPTION

Fiber optic communication has in many cases provided increased immunity to electrical interference due to electrostatic discharge (ESD) and conductive and radiative electromagnetic fields. Many users have reported significant reductions in the severity and frequency of lightning strike damage to electrical equipment after proper installation of fiber optic communication devices between stack-mounted and control room equipment.

The FibreLink III Standalone Version fiber optics interface is a repeater device designed to create an electrically isolated fiber optic bridge between two FTT10A LONWORKS[®] twisted pair networks.

The Stack Unit is packaged in a NEMA4X enclosure and as such is designed for use in outdoor applications. The Control Room Unit is packaged in an extruded aluminum case and is not suitable for outdoor use. The Control Room Unit is intended for use in indoor environments such as control rooms and temperature controlled Continuous Emission Monitoring System (CEMS) shelters. Both units contain an identical, interchangeable circuit board that converts FTT10A twisted pair network signals into fiber optic signals running at approximately 78K BAUD. The Stack Unit contains a transformer to reduce power mains voltage to approximately 24VAC for use by the internal circuit board. The Control Room Unit is shipped with a wall transformer that performs the equivalent function. See Figure 1, FibreLink III Block Diagram.

All network packets are passed between both ends of the network. Routing functions are not supported. These features make the FibreLink III ideally suited for use with the LightHawk[®] 560, LaserHawk[®] 360, Ultraflow 150, and Model 550.

The fiber optic signals in the FibreLink III are multimode near infrared with a nominal wavelength of 850 nanometers (nm). The fiber emitters are based on light emitting diode (LED) technology. The device is designed for use with ST connectors and 62.5/125 micron multimode fiber. Two fibers are required for operation, though the installation of spare fibers is strongly encouraged.

For an overview of proper installation practice, consult the installation drawings in Appendix B of this manual.

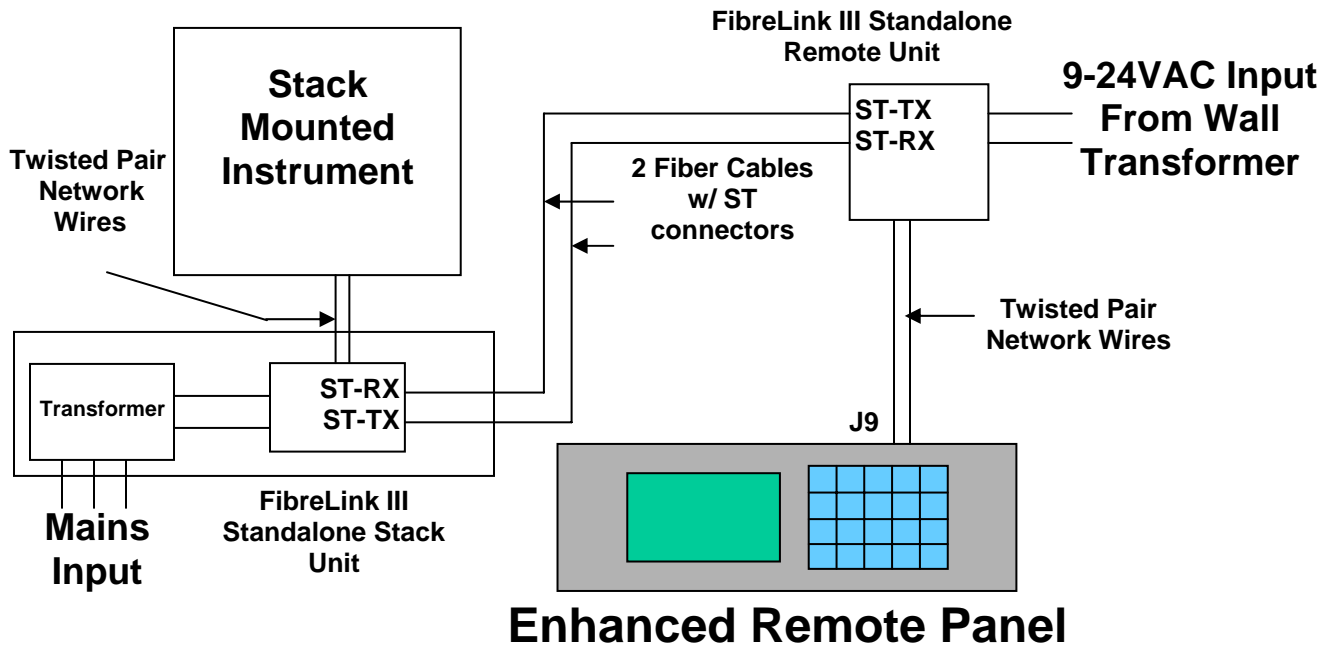

Figure 1
FibreLink III Block Diagram

3.0 SPECIFICATIONS

PHYSICAL DIMENSIONS

Stack Unit	5-3/8" (137mm) (L) X 11-1/2" (292mm) (W) X 13-1/2" (343mm) (H)
Control Room Unit	1-7/8" (47.6mm) (L) X 6-1/4" (82.6mm) (W) X 5-1/8" (130mm) (H)

PHYSICAL WEIGHTS

Stack Unit	8.9 lbs. (4.04 kg)
Control Room Unit	1.2 lbs. (0.544 kg)

OPTICAL CHARACTERISTICS

Nominal Wavelength	850 nm
Fiber Optic Connectors	ST Style
Number of Fibers Required for Operation	2
Cable Type	62.5/125 micron, Multimode
Maximum Fiber Optic Cable Length	6,561.7 feet (2 km) (Assuming attenuation of 3.75 db/km from cable, 0.5 dB each for two ST connectors per fiber and 3dB of margin.)

POWER REQUIREMENTS

Stack Unit	-01: 98-132 VAC, 47-63Hz, Single Phase, 8 VA Maximum, Fuses: 0.5 Amp, 250V, SLO-BLO -02: 230 VAC, 47-63Hz, Single Phase, 8 VA Maximum Fuses: 0.25 Amp, 250V, SLO-BLO
Control Room Unit	9-24 VAC, 47-63Hz, Single Phase, 1.5 VA Maximum -01: provided with Wall Mount Transformer for 115VAC -02: provided with Wall Mount Transformer for 230VAC

AMBIENT OPERATING CONDITIONS

Stack Unit	Temperature Range: -40 to +150°F (-40 to +65.6°C) Relative Humidity Range: 5% to 100% condensing Enclosure Rating: NEMA4X
Control Room Unit	Temperature Range: -40 to +150°F (-40 to +65.6°C) Relative Humidity Range: 5% to 95% noncondensing Enclosure Rating: NEMA1

WIRING REQUIREMENTS

Network Transceiver Type	Free Topology Transceiver (FTT10A)
Cable Type	2 conductor shielded twisted pair, 16 AWG (ALPHA 5610B1601, or equivalents). See Note 2.
Termination Style	Jumper Selectable Single / Double Termination (Internal)
Maximum Wire Length Between Optical Head & FibreLink III	820 feet (0.25 km) [must be Double Terminated] SEE NOTE 1.
Maximum Wire Length Between Enhanced Remote Panel & FibreLink III	65 feet (20M) [must be Double Terminated] SEE NOTE 1.

NOTES

1. Since the most frequent application of the FibreLink is as a means to reduce lightning strike damage to stack-mounted equipment, short distances of wire cable are highly encouraged. Long lengths of wire will reduce the effectiveness of the equipment for this purpose.
2. Shielded cable drain wires must be terminated as per installation drawing guidelines using shield termination kit, TML Part Number 0650-0400-01.
3. FibreLink III units function as repeaters, i.e., all network traffic is passed through in both directions.
4. The FibreLink III Standalone unit is designed for use with the 550 Opacity Monitor, the LightHawk 560 Opacity Monitor, the 150 Ultraflow & the 360 Backscatter Monitor.

(This page intentionally left blank.)

APPENDIX A
SPARE PARTS

(This page intentionally left blank.)

RECOMMENDED SPARE PARTS

The important spare parts for the FibreLink III are the internal circuit board, which is interchangeable between the Stack and Remote Units, and the external fuses for the Stack Unit. The following table contains recommended quantities based on the number of operating links at a given plant.

Recommended Quantity	FibreLinks in Service At Plant*	Part Number	Description
1	1 to 2	1903-2200-01	FibreLink III Standalone Circuit Board Assembly
2	3 to 5		
3	6 or more		
4	1 to 2	527367	0.5 Amp, 250 V, SLO-BLO Fuse (for Stack Unit)
8	3 to 5		
12	6 or more		

* Each FibreLink in this table is comprised of 2 circuit boards (one each for the Stack and Remote Units).

(This page intentionally left blank.)

APPENDIX B
DRAWINGS

(This page intentionally left blank.)

REVISIONS				
ZONE	SYM.	DESCRIPTION	DATE	APPD.
	C	ADDED THIS SHT PER DCN #1808-0003C	4-15-03	DMB
	D	PER DCN 1808-0003D	12-2-03	DMB
	E	PER DCN 1808-0003E	11-3-11	ELM

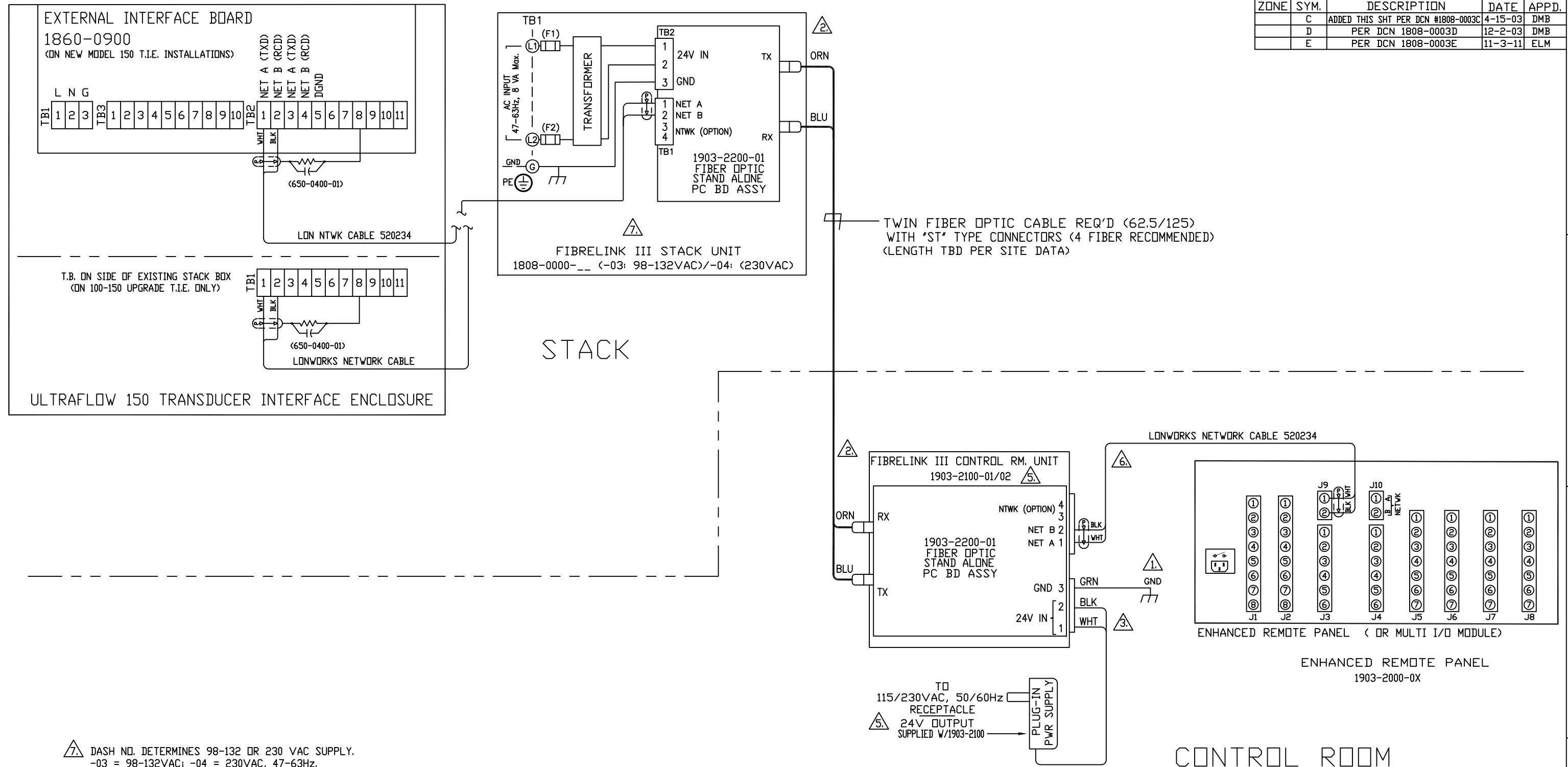

- ⚠ DASH NO. DETERMINES 98-132 OR 230 VAC SUPPLY. -03 = 98-132VAC; -04 = 230VAC, 47-63Hz.
- ⚠ LOCATE CONTROL ROOM UNIT IN CLOSE PROXIMITY TO ENHANCED REMOTE PANEL FOR BEST RESULTS.
- ⚠ DASH NO. DETERMINES 115 OR 230 VAC SUPPLY. -01 = 115VAC; -02 = 230VAC, 50/60Hz
- 4. SEE TML SYSTEM WIRING DIAGRAM 1900-0004 OR 1900-0005 (MODEL 100 TO 150 UPGRADE) FOR ADDITIONAL WIRING AT EACH END OF NETWORK.
- ⚠ WHT/BLK WIRE COLOR SHOWN FOR REFERENCE ONLY. (AC INPUT WIRES INTERCHANGEABLE)
- ⚠ CONNECT BOTH FIBERS AT EACH END.

NOTES: ⚠ GROUND TERMINAL ON CONTROL RM. UNIT SHOULD BE TIED TO APPROPRIATE EARTH GROUND TERMINAL.

CONTROL ROOM

DIMENSIONAL TOLERANCES UNLESS OTHERWISE SPECIFIED			USED ON		TELEDYNE MONITOR LABS A Teledyne Technologies Company
FRACTIONS	DECIMALS	ANGLES	DASH NO	NEXT ASSEMBLY	
0 TO 4 1/32	.005	30°/30'		150 TOP	THIS DOCUMENT CONTAINS INFORMATION PROPRIETARY AND CONFIDENTIAL TO TELEDYNE MONITOR LABS AND IS FURNISHED UNDER THE EXPRESS CONDITION THAT THE INFORMATION CONTAINED HEREIN WILL NOT BE REPRODUCED, REPRISSED, DISCLOSED OR DISSEMINATED TO OTHERS OR USED FOR ANY PURPOSE OTHER THAN IN CONNECTION WITH THE EVALUATION THEREOF WITHOUT THE PRIOR WRITTEN CONSENT OF TELEDYNE MONITOR LABS.
4 TO 8 1/16	.003	RMS FINISH			
8 AND UP 1/8					
ALL DIMENSIONS ARE IN INCHES DO NOT SCALE THIS DRAWING					
AUTHORIZATION			TITLE		SYSTEM WIRING DIAGRAM 150 WITH FIBRELINK III OPTION (SUPPLEMENTAL DRAWING)
DRAWN DCH 3-24-03			MAT'L.		
CHECKED DMB 7-11-03			FINISH		
DESIGNED DCH 3-24-03			JIG NO.		
ENGINEERED DMB 7-11-03			SCALE		
PRODUCTION PD 7-11-03			SHEET		
Q.A. AS 7-11-03			4 OF 6		

PROJECTION

D	DRAWING NO.	LATEST REVISION
	1808-0003	

REVISIONS				
ZONE	SYM.	DESCRIPTION	DATE	APPD.
	C	ADDED THIS SHT PER ECN #1808-0003C	4-15-03	DMB
	D	PER DCN 1808-0003D	12-2-03	DMB
	E	PER DCN 1808-0003E	11-3-11	ELM

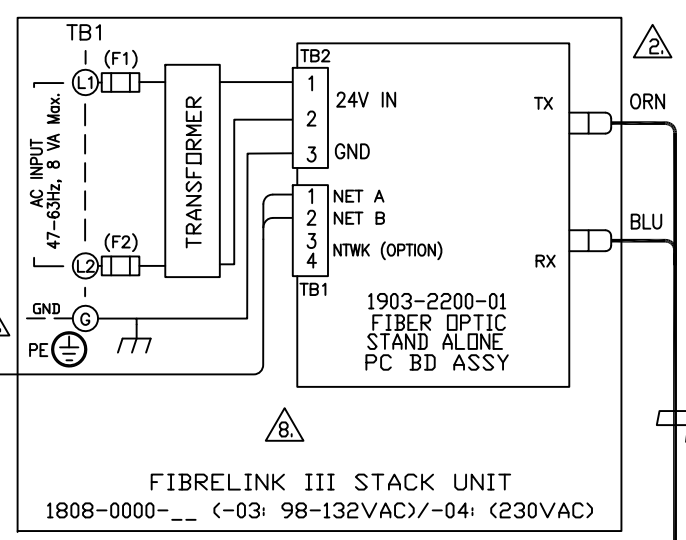
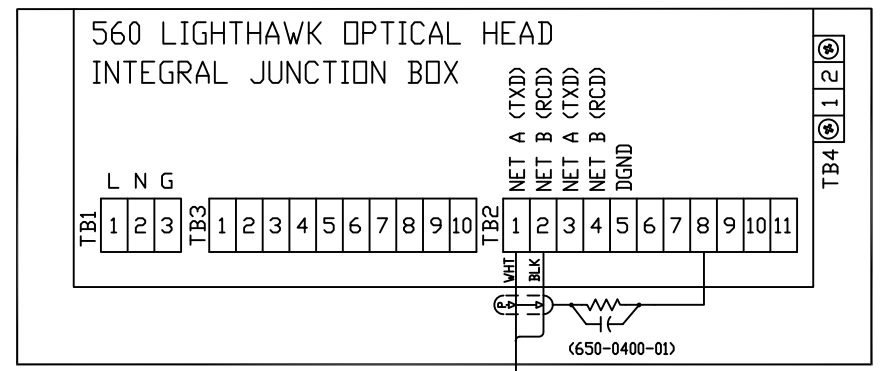

TWIN FIBER OPTIC CABLE REQ'D (62.5/125) WITH 'ST' TYPE CONNECTORS (4 FIBER RECOMMENDED) (LENGTH TBD PER SITE DATA)

STACK

CONTROL ROOM

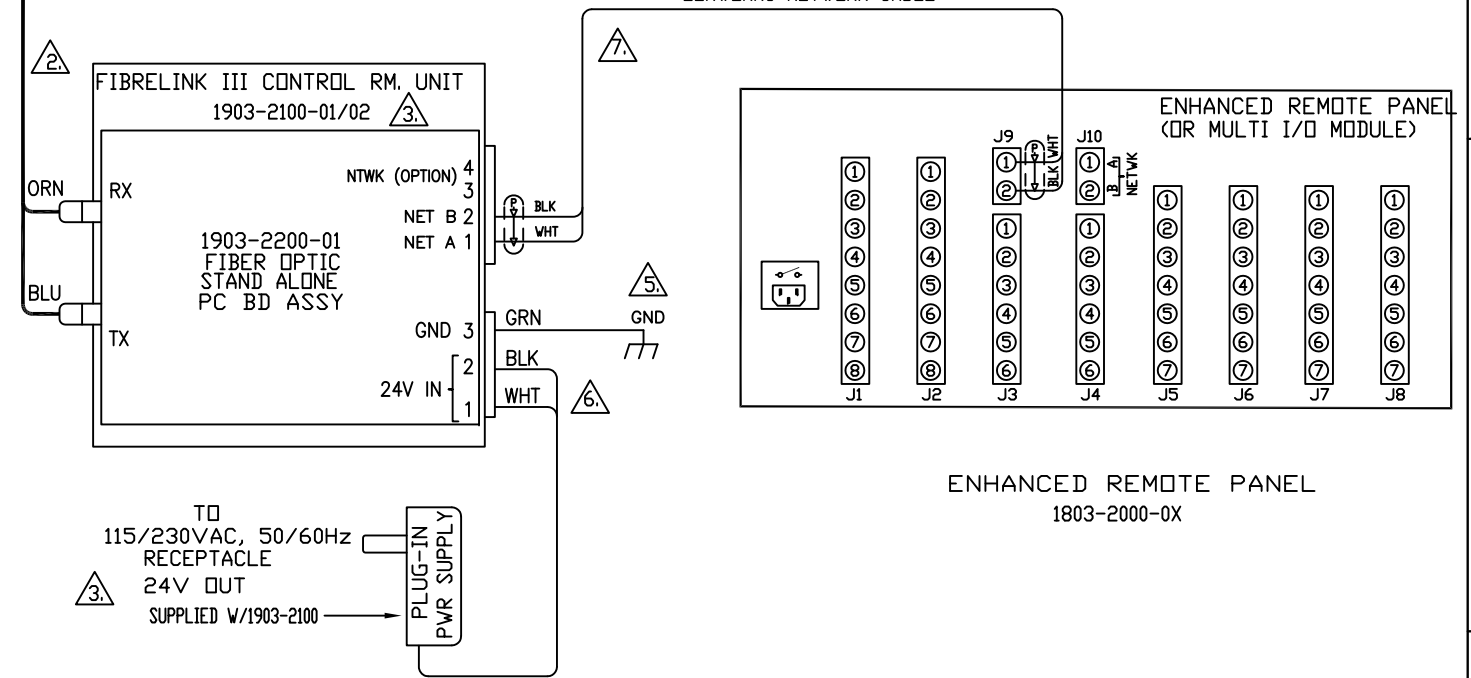
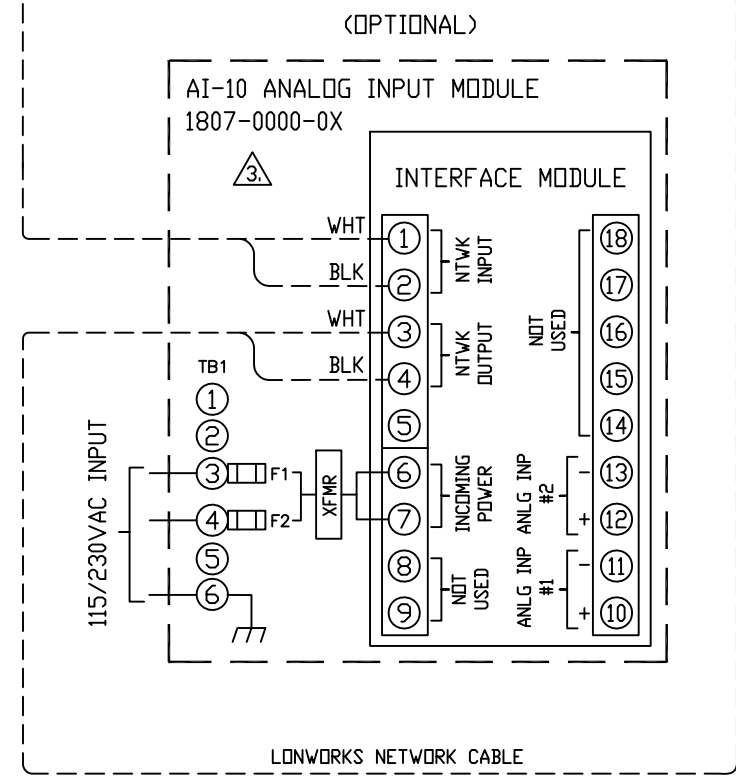

- NOTES:
- ⑥ WHT/BLK WIRE COLOR SHOWN FOR REFERENCE ONLY. (AC INPUT WIRES ARE INTERCHANGEABLE)
 - ⑤ GROUND TERMINAL ON MODULE SHOULD BE TIED TO APPROPRIATE EARTH GROUND TERMINAL.
 - 4. SEE TML SYSTEM WIRING DIAGRAM 1860-0001 FOR ADDITIONAL WIRING AT EACH END OF NETWORK.
 - ③ DASH NO. DETERMINES 115 OR 230 VAC SUPPLY. -01 = 115VAC; -02 = 230VAC, 50/60Hz.
 - ② CONNECT BOTH FIBERS AT EACH END OF FIBER CABLE.
 - ① FIBRELINK III OPTION MAY BE USED WITH ANY OF THE NON-DIRECT INTERFACE VERSIONS. IF THE ANALOG INPUT MODULE OPTION IS PROVIDED, CONNECT THE 560 OPTICAL HEAD TO THE ANALOG INPUT MODULE, THEN THE FIBRELINK II MODULE TO THE ANALOG MODULE AS SHOWN.

- ⑧ DASH NO. DETERMINES 98-132 OR 230 VAC SUPPLY. -03 = 98-132VAC; -04 = 230VAC, 47-63Hz.
- ⑦ LOCATE CONTROL ROOM UNIT IN CLOSE PROXIMITY TO THE ENHANCED REMOTE PANEL FOR BEST RESULTS.

DIMENSIONAL TOLERANCES UNLESS OTHERWISE SPECIFIED			USED ON		TELEDYNE MONITOR LABS A Teledyne Technologies Company
FRACTIONS	DECIMALS	ANGLES	DASH NO	NEXT ASSEMBLY	
6 TO 4 41/32	.001	30°-90°		560 TOP	THIS DOCUMENT CONTAINS INFORMATION PROPRIETARY AND CONFIDENTIAL TO TELETYPE MONITOR LABS AND IS FURNISHED WITH THE EXPRESS UNDERSTANDING THAT INFORMATION CONTAINED HEREIN WILL NOT BE REPRODUCED, REPAIRED, DISCLOSED OR DISSEMINATED TO OTHERS OR USED FOR ANY PURPOSE OTHER THAN IN CONNECTION WITH THE EVALUATION SERVICE WITHOUT THE PRIOR WRITTEN CONSENT OF TELETYPE MONITOR LABS.
4 TO 6 41/32	.002				
6 AND UP 41/32	.005				
ALL DIMENSIONS ARE IN INCHES UNLESS OTHERWISE SPECIFIED					
AUTHORIZATION			TITLE		SYSTEM WIRING DIAGRAM 560 WITH FIBRELINK III OPTION (SUPPLEMENTAL DRAWING)
DRAWN DCH 4-15-03			FINISH		
CHECKED DMB 7-11-03			SCALE NTS		
DESIGNED DCH 4-15-03			SHEET 5 OF 6		
ENGINEERED DMB 7-11-03			DRAWING NO. 1808-0003		
PRODUCTION PD 7-11-03			LATEST REVISION E		
G.A. AS 7-11-03					



REVISIONS				
ZONE	SYM.	DESCRIPTION	DATE	APPD.
	C	ADDED THIS SHT PER ECN #1808-0003C	4-15-03	DMB
	D	PER DCN 1808-0003D	12-5-03	DMB
	E	PER DCN 1808-0003E	11-3-11	ELM

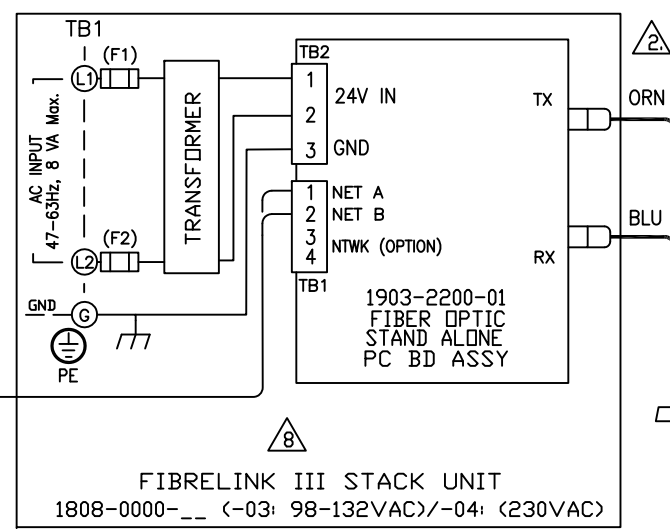
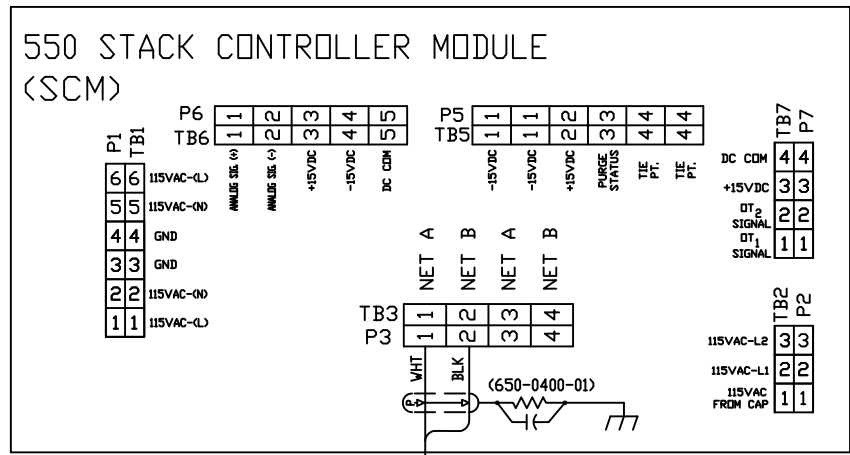

TWIN FIBER OPTIC CABLE REQ'D (62.5/125) WITH 'ST' TYPE CONNECTORS (4 FIBER RECOMMENDED) (LENGTH TBD PER SITE DATA)

STACK

CONTROL ROOM

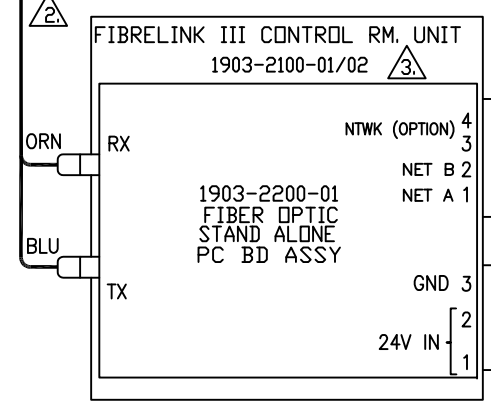
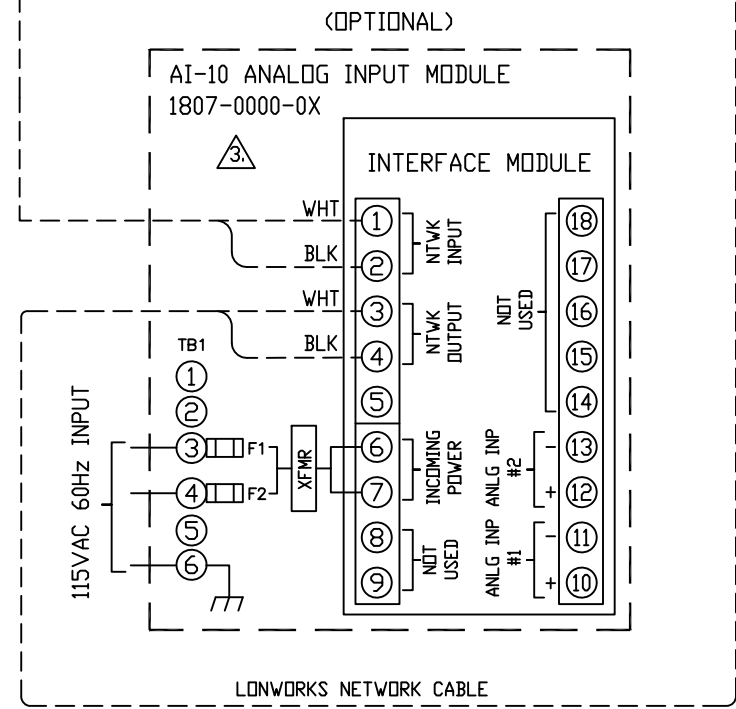

TO 115/230VAC, 50/60Hz RECEPTACLE 24V OUTPUT SUPPLIED W/1903-2100

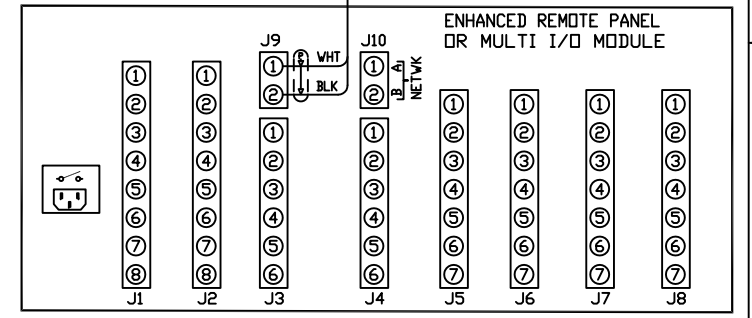

ENHANCED REMOTE PANEL 1803-0000-XX

- NOTES:
- Ⓐ WHT/BLK WIRE COLOR SHOWN FOR REFERENCE ONLY. (AC INPUT)
 - Ⓔ GROUND TERMINALS ON EACH END SHOULD BE TIED TO APPROPRIATE EARTH GROUND TERMINAL.
 - 4. SEE TML SYSTEM WIRING DIAGRAM 600-0088 FOR ADDITIONAL WIRING AT EACH END OF NETWORK.
 - Ⓕ DASH NO. DETERMINES 115 OR 230 VAC SUPPLY. -01 = 115VAC; -02 = 230VAC, 50/60Hz.
 - Ⓖ BOTH FIBERS MUST BE CONNECTED AT EACH END OF CABLE FOR PROPER OPERATION.
 - Ⓗ FIBRELINK III OPTION MAY BE USED WITH THE MODEL 550 OPACITY MONITOR. IF THE ANALOG INPUT MODULE OPTION IS PROVIDED, CONNECT THE 550 STACK CONTROL MODULE TO THE ANALOG INPUT MODULE, THEN THE FIBRELINK III MODULE TO THE ANALOG MODULE AS SHOWN.

- Ⓒ DASH NO. DETERMINES 98-132 OR 230 VAC SUPPLY. -03 = 98-132VAC; -04 = 230VAC, 47-63Hz.
- Ⓙ LOCATE CONTROL ROOM UNIT IN CLOSE PROXIMITY TO THE ENHANCED REMOTE PANEL FOR BEST RESULTS.

DIMENSIONAL TOLERANCES UNLESS OTHERWISE SPECIFIED			USED ON		TELEDYNE MONITOR LABS A Teledyne Technologies Company
FRACTIONS	DECIMALS	ANGLES	DASH NO	NEXT ASSEMBLY	
0 TO 4 1/32	.001	30°-90°		550 TOP	THIS DOCUMENT CONTAINS INFORMATION PROPRIETARY AND CONFIDENTIAL TO TELETYPE MONITOR LABS AND IS FURNISHED UNDER THE EXPRESS CONDITION THAT THE INFORMATION CONTAINED HEREIN WILL NOT BE REPRODUCED, REPRINTER, DISCLOSED OR DISSEMINATED TO OTHERS OR USED FOR ANY PURPOSE OTHER THAN IN CONNECTION WITH THE EVALUATION HEREOF WITHOUT THE PRIOR WRITTEN CONSENT OF TELETYPE MONITOR LABS.
4 TO 8 1/16	.002				
8 AND UP 1/8	.005				
ALL DIMENSIONS ARE IN INCHES UNLESS OTHERWISE SPECIFIED					
AUTHORIZATION			TITLE		SYSTEM WIRING DIAGRAM (SUPPLEMENTAL DRAWING)
BY DATE			SCALE		
DRAWN DCH 4-15-03			SHEET 6 OF 6		
CHECKED DMB 7-11-03			DRAWING NO.		
DESIGNED DCH 4-15-03			1808-0003		
ENGINEERED DMB 7-11-03			LATEST REVISION		
PRODUCTION PD 7-11-03			E		
G.A. AS 7-11-03					



REVISIONS				
ZONE	SYM.	DESCRIPTION	DATE	APPD.
	A	RELEASED FOR PRODUCTION	12-15-05	ELM
	B	PER DCN 1810-0016B	3-14-07	ELM
	C	PER DCN 1810-0016C	11-30-11	ELM

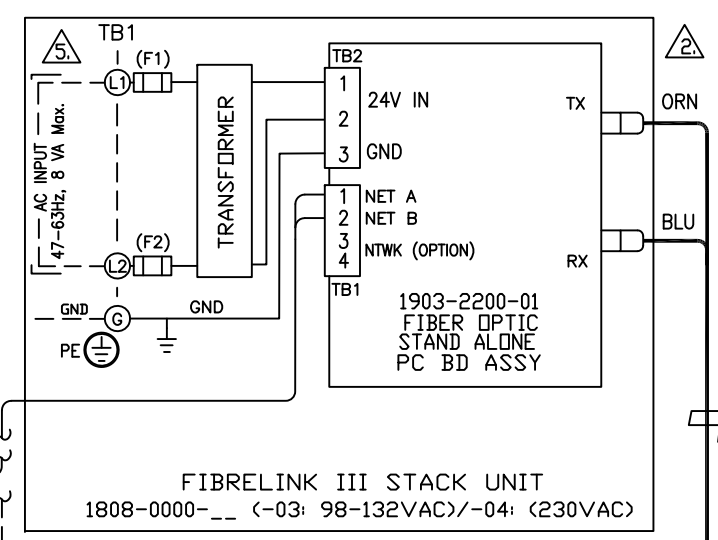
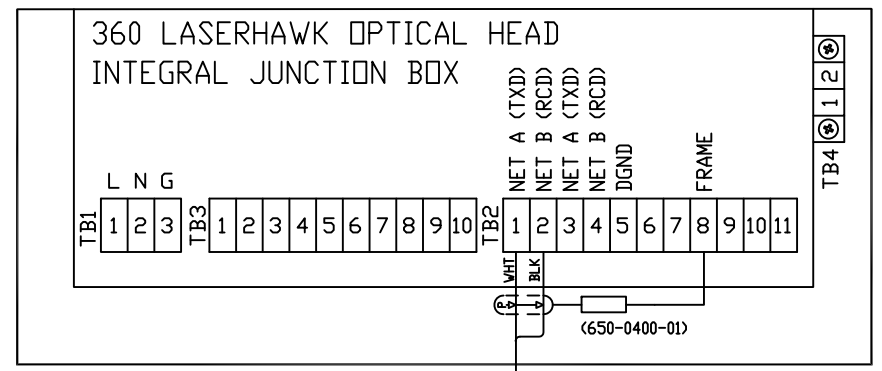

TWIN FIBER OPTIC CABLE REQ'D (62.5/125) WITH 'ST' TYPE CONNECTORS (4 FIBER RECOMMENDED) (LENGTH TBD PER SITE DATA)

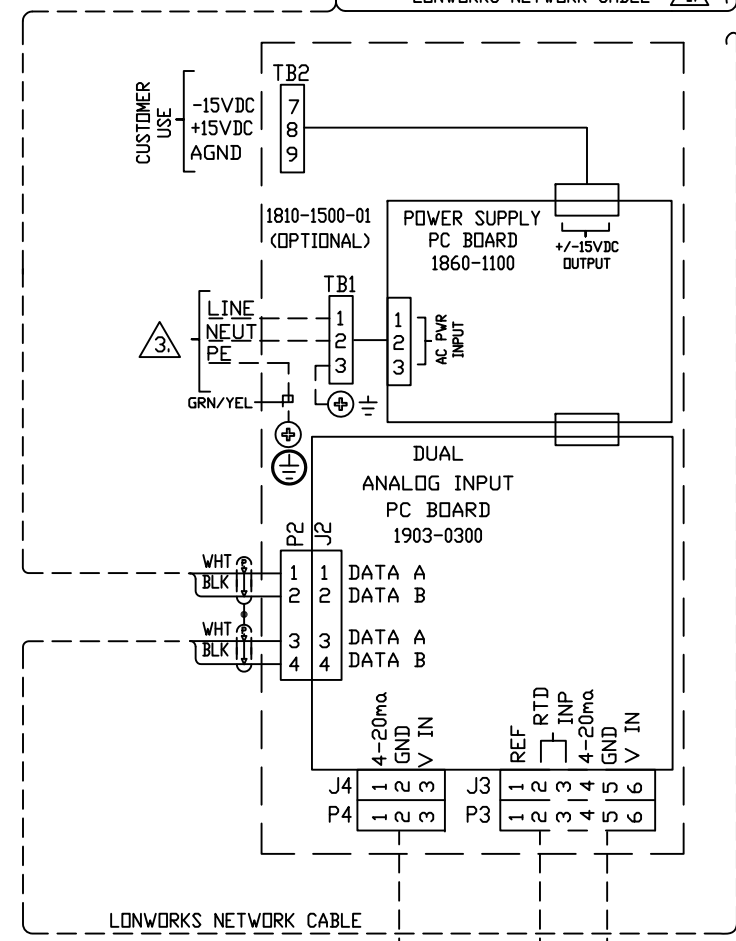

OPTIONAL WIRING FOR DUAL ANALOG INPUT MODULE

STACK

CONTROL ROOM

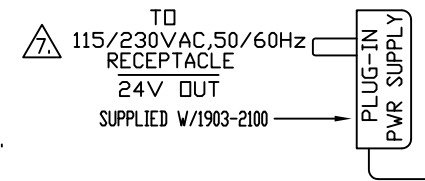
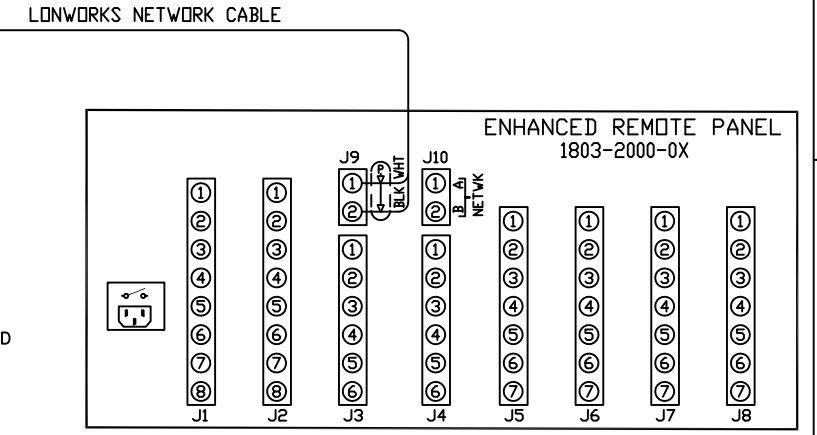
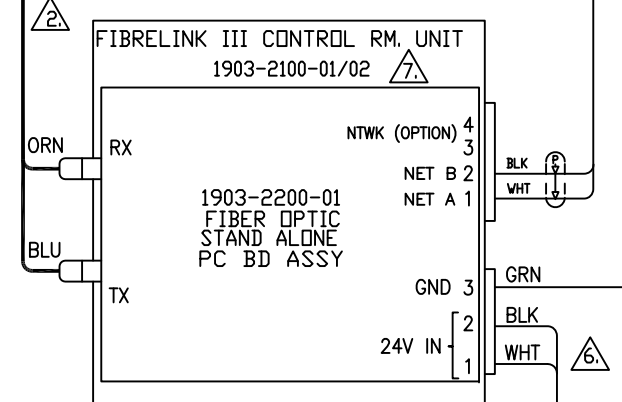

- NOTES:
- ⚠ DASH-01 = 115VAC, -02 = 230VAC SUPPLY REQUIRED.
 - ⚠ WHT/BLK WIRE COLOR SHOWN FOR REFERENCE ONLY. (AC INPUT WIRES ARE INTERCHANGEABLE)
 - ⚠ TERMINATE 'PE' GROUND WIRE UNDER BOTTOM NUT, THEN TB1 GROUND WIRE UNDER TOP NUT.
 - 4. SEE TML SYSTEM WIRING DIAGRAM 1810-0012 FOR ADDITIONAL WIRING AT EACH END OF NETWORK.
 - ⚠ POWER REQUIREMENT IS 85-245VAC, 50/60Hz, 1Ø, 35VA.
 - ⚠ CONNECT BOTH FIBERS AT EACH END OF FIBER CABLE.
 - ⚠ FIBRELINK III OPTION MAY BE USED WITH THE NON-DIRECT INTERFACE VERSION. IF THE ANALOG INPUT MODULE OPTION IS PROVIDED, CONNECT THE 360 OPTICAL HEAD TO THE ANALOG INPUT MODULE, THEN THE FIBRELINK III MODULE TO THE ANALOG MODULE AS SHOWN.

SUPPLEMENTAL DRAWING ONLY. SEE 1810-0012.

DIMENSIONAL TOLERANCES UNLESS OTHERWISE SPECIFIED		USED ON		TELEDYNE MONITOR LABS	
FRACTIONS	DECIMALS	DASH NO	NEXT ASSEMBLY	A Teledyne Technologies Company	
6 TO 4 #1/32	.005		360 TOP	THIS DOCUMENT CONTAINS INFORMATION PROPRIETARY AND CONFIDENTIAL TO TELETYPE MONITOR LABS AND IS FURNISHED UNDER THE EXPRESS CONDITION THAT THE INFORMATION CONTAINED HEREIN WILL NOT BE REPRODUCED, REPERATED, DISCLOSED OR DISSEMINATED TO OTHERS OR USED FOR ANY PURPOSE OTHER THAN IN CONNECTION WITH THE EVALUATION HEREOF WITHOUT THE PRIOR WRITTEN CONSENT OF TELETYPE MONITOR LABS.	
4 TO 8 #1/16	.008			TITLE	
8 AND UP #1/8	.010			SYSTEM WIRING DIAGRAM	
ALL DIMENSIONS ARE IN INCHES DD NOT SCALE THIS DRAWING				360 WITH FIBRELINK III OPTION (SUPPLEMENTAL DRAWING)	
AUTHORIZATION				FINISH	
BY	DATE				
DRAWN DCH	12-15-05				
CHECKED ELM	1-03-06				
DESIGNED DCH	12-15-05				
ENGINEERED ELM	1-03-06				
PRODUCTION GA	1-04-06				
Q.A. AS	1-04-06				
SCALE NTS		SHEET 1 OF 1		DRAWING NO. 1810-0016	
				LATEST REVISION C	



REVISIONS				
ZONE	SYM.	DESCRIPTION	DATE	APPD.
A		PER DCN 1808-0009A	2-9-04	DMB
B		PER DCN 1808-0009B	11-16-11	ELM

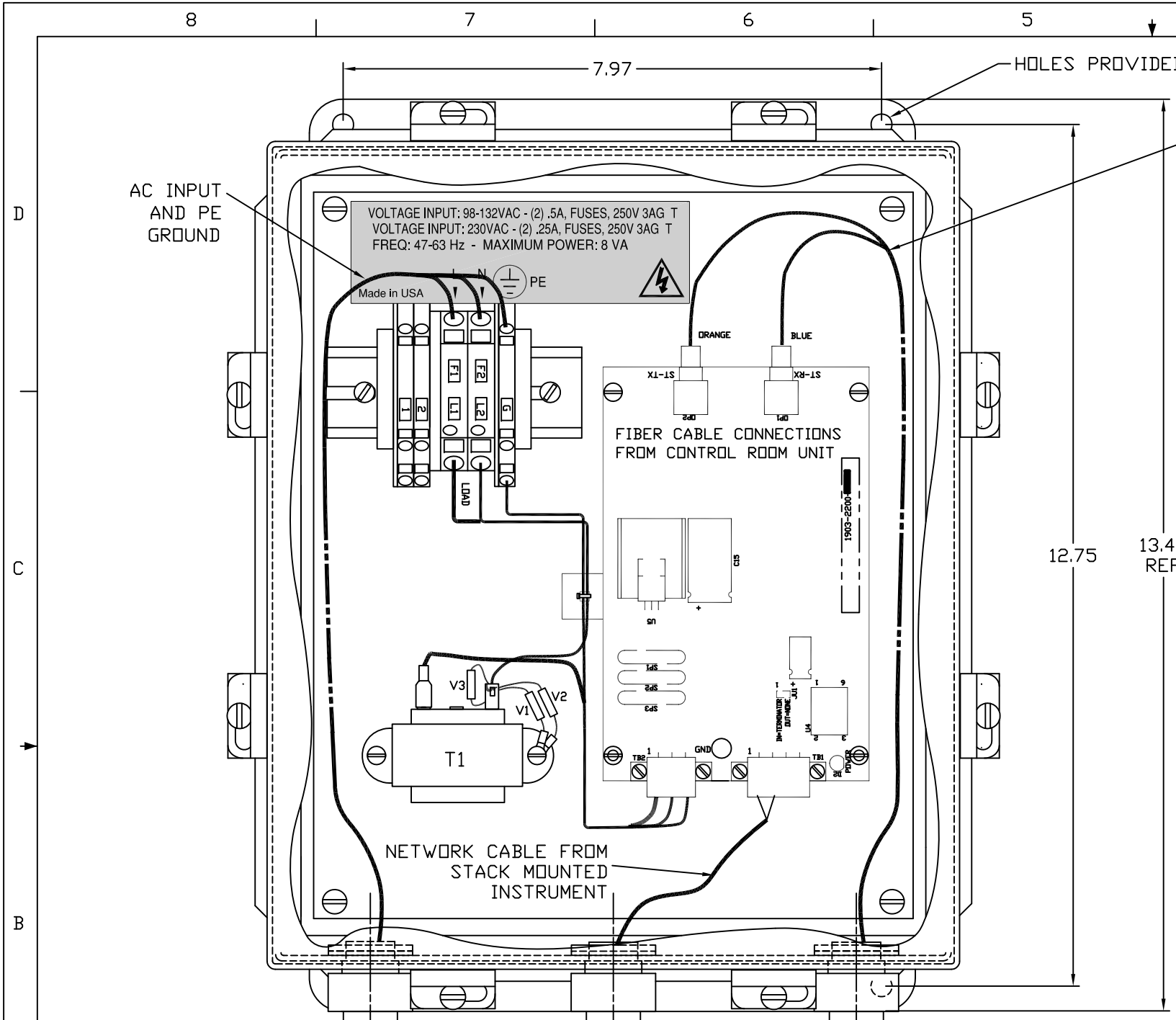

HOLES PROVIDED ARE FOR 1/4" HARDWARE

DO NOT BEND SHARP, USE MIN RADIUS OF 3"

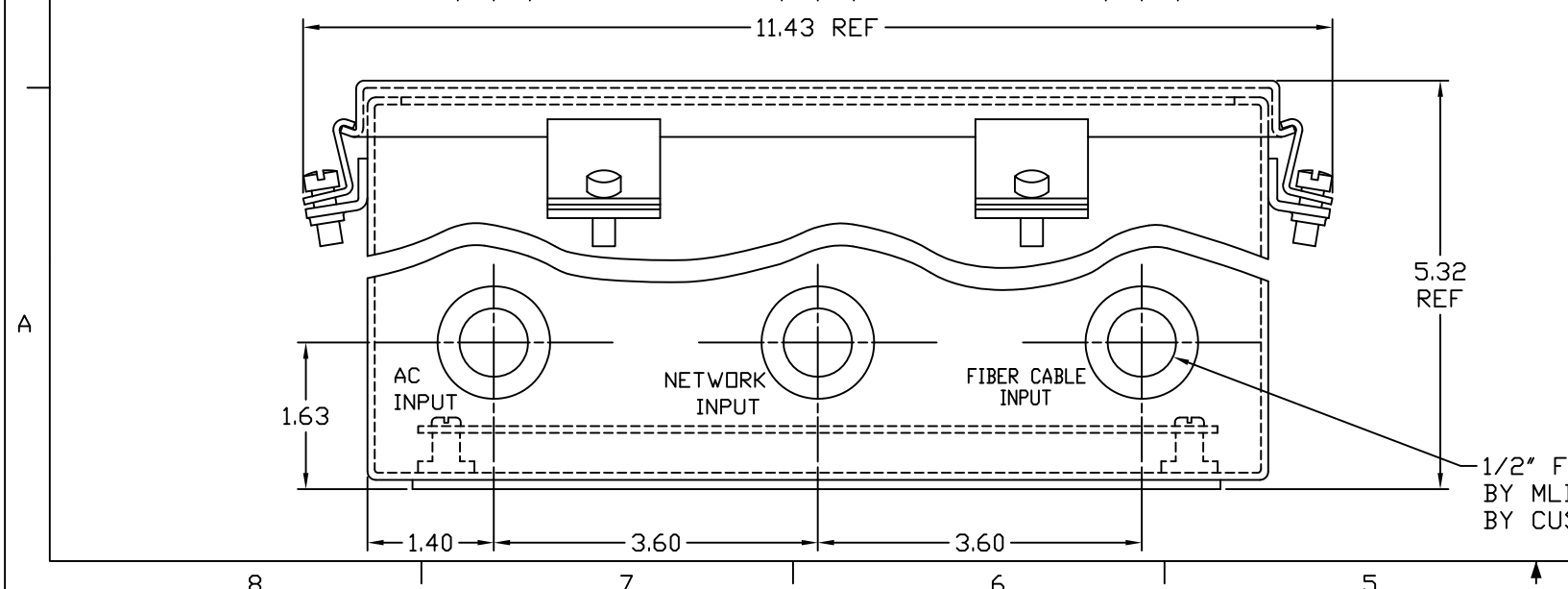
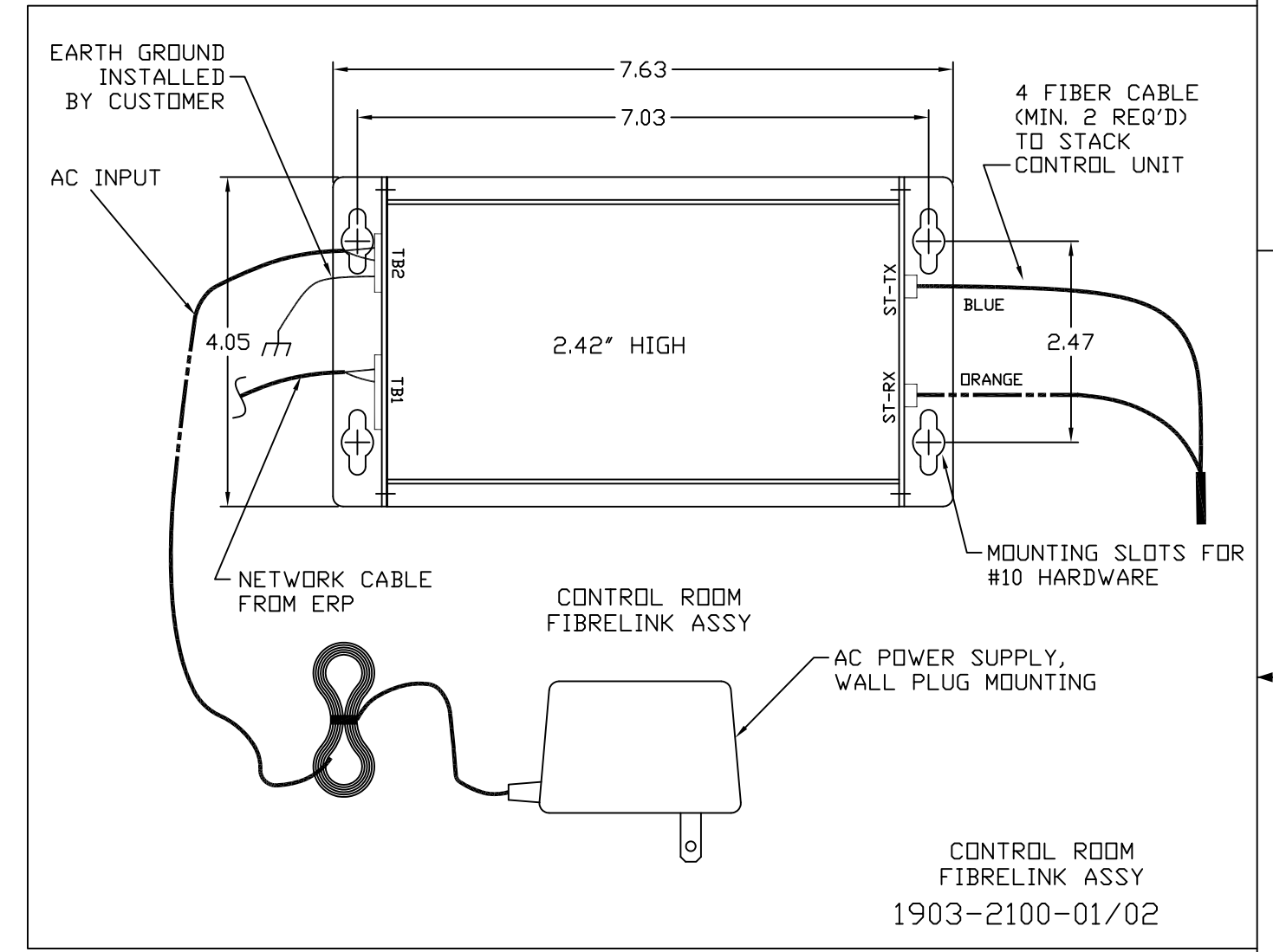

2. FIBERLINK III INTERFACE CONSISTS OF TWO CONTROL UNITS. ONE IS STACK MOUNTED IN A NEMA 4X ENCLOSURE AND THE OTHER IS LOCATED IN THE CONTROL ROOM, SUPPLIED WITH A WALL PLUG-IN POWER SUPPLY. THE NETWORK CABLES CONNECT BETWEEN THE TML ELECTRONICS AND THE CONTROL UNITS AT EACH LOCATION. THE FIBER CABLE CONNECTS BETWEEN THE CONTROL UNITS.
1. FOR WIRING SEE DRAWING 1808-0003, SHEET 6 (550);
 1808-0003, SHEET 5 (560);
 1808-0003, SHEET 4 (150).
 1810-0016, SHEET 1 (360).

NOTES:

DIMENSIONAL TOLERANCES UNLESS OTHERWISE SPECIFIED		USED ON		TELEDYNE MONITOR LABS A Teledyne Technologies Company	
FRACTIONS	DECIMALS	DASH NO	NEXT ASSEMBLY	THIS DOCUMENT CONTAINS INFORMATION PROPRIETARY AND CONFIDENTIAL TO TELEDYNE MONITOR LABS AND IS FURNISHED UNDER THE EXPRESS CONDITION THAT THE INFORMATION CONTAINED HEREIN WILL NOT BE REPRODUCED, REPRINTERED, DISCLOSED OR DISSEMINATED TO OTHERS OR USED FOR ANY PURPOSE OTHER THAN IN CONNECTION WITH THE EVALUATION HEREOF WITHOUT THE PRIOR WRITTEN CONSENT OF TELEDYNE MONITOR LABS.	
0 TO 4 41/32	.001	-01	550/560/150/360	TITLE	
4 TO 8 41/16	.002			FIBERLINK III INSTALLATION DRAWING	
8 AND UP 41/8	.005			FINISH	
ALL DIMENSIONS ARE IN INCHES DO NOT SCALE THIS DRAWING					
AUTHORIZATION					
DRAWN		BY	DATE		
CHECKED		BY	DATE		
DESIGNED		BY	DATE		
ENGINEERED		BY	DATE		
PRODUCTION		BY	DATE		
G.A.		BY	DATE		
SCALE		SHEET		DRAWING NO.	
1:1		1 of 1		1808-0009	
				LATEST REVISION	
				B	